

Disc Springs are conically-shaped precision components designed to be axially loaded. Disc Springs can be statically loaded either continuously or intermittently, or dynamically subjected to continuous load cycling. What sets Disc Springs apart from other types of springs is that deflection of the Disc at a given load is predictable making it possible to calculate the minimum cycle life. Due to their predictability, high reliability, and unparalleled fatigue life, Disc Springs are preferred over all other types of springs in critical applications such as safety valves, clutch and brake mechanisms for elevators and heavy equipment, and supports for industrial pipe systems. Disc Springs can be used individually or assembled into stacks to achieve the forcedeflection characteristics required for the application. This White Paper details the different methods of stacking Disc Springs, and how to determine the proper stack configuration for a particular application.

To achieve the optimal Disc Spring performance, it is best to keep the working deflection between 15% and 75% of full deflection as it is in this range that measured results most accurately match the theoretical characteristics of the Disc Spring. If a single Disc Spring is not capable of the force/deflection characteristics the application requires, Disc Springs can be stacked in series, parallel or combination to achieve the requirements (See *Below: Methods of Stacking and Figure 1*).

METHODS OF STACKING

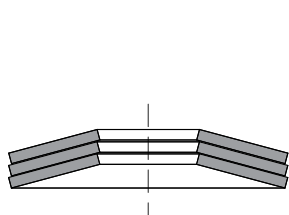

IN PARALLEL

Deflection: Same as single Disc

Force: Single Disc multiplied by the number of Discs

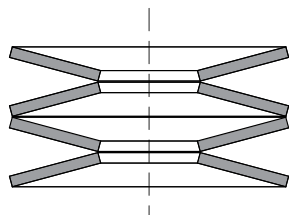

IN SERIES

Deflection: Single Disc multiplied by the number of Discs

Force: Same as single Disc

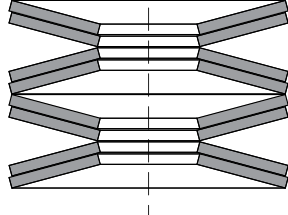

IN COMBINATION

Deflection: Single Disc multiplied by the number of Discs in series

Force: Single Disc multiplied by the number of parallel Discs in a set

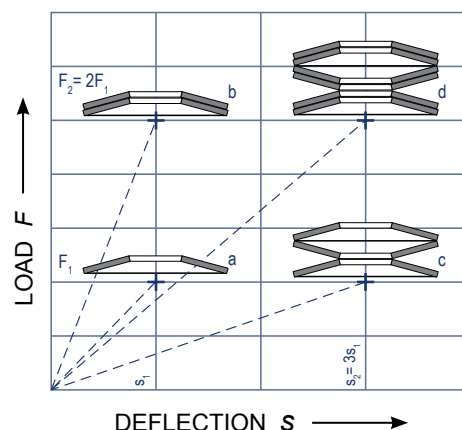

Figure 1

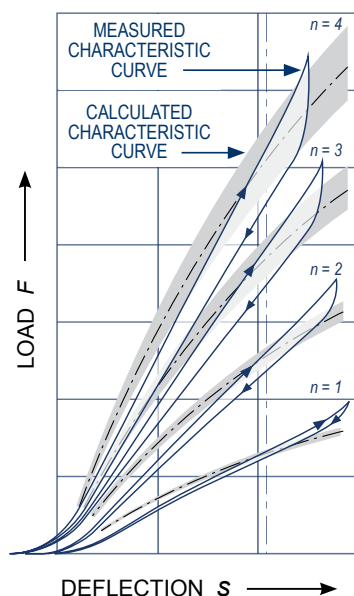

Figure 2

Friction between Disc Springs stacked in parallel must be considered. Factors affecting friction include the number of Discs stacked in parallel, the amount of Disc deflection, Disc lubrication and surface finish of the Discs and guiding elements. A reasonable allowance is 2 – 3% for each sliding surface. Addition of friction in parallel stacked Discs results in an actual load/deflection curve that is different from the theoretical curve. Actual loads are higher when a load is applied and reduced when the load is removed. This hysteresis results in a damping affect that increases with thicker Discs or more Discs stacked in parallel (Figure 2).

Friction between sliding surfaces should be minimized to reduce deviation from theoretical predictions and reduce heat buildup detrimental to life of the Disc. Disc Springs stacked in parallel should be lubricated with a solid lubricant such as molybdenum disulphide and limited to a maximum of 4 Discs in parallel. Friction will be less in a vertically oriented stack than in a horizontally loaded stack. In dynamic applications there is a “running in” period where friction is reduced as surface finish of sliding surfaces and contact surfaces wear and smooth due to part on part contact.

When stacking Disc Springs, a wide range of force/deflection characteristics are possible; the stack can be designed with specific load curves to meet the application requirements with both progressive and regressive possible (Figure 3).

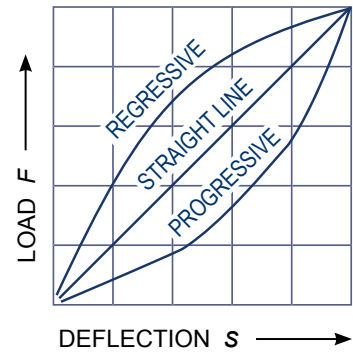

Figure 3

STACK CONSTRUCTION

It is preferable to configure the stack to have an even number of Disc Springs with the outer edge of the Disc Spring positioned at each end of the stack to aid stability. Due to various application restrictions, it may not always be possible to use a stack with an even number of Disc Springs. When a stack configuration uses an odd number of Disc Springs, the outer edge of the Disc Spring should be oriented to the end which the force is applied – the moving end of the stack.

Shorter stacks are more efficient, which is of particular importance for dynamic applications. As a result of friction between the Disc Springs as well as the guiding mandrel or sleeve, the Disc Springs at the moving end of the stack tend to deflect more than the Disc Springs at the opposite end. Using the largest practical diameter Disc Spring will reduce the number of Disc Springs per stack, and the total stack height. It is recommended that the overall stack height does not exceed 3 times the external diameter of the Disc Spring or 10 Discs in series. If the application requires, taller stacks can be divided with flat washers to provide stability.

EVEN NUMBER OF DISCS

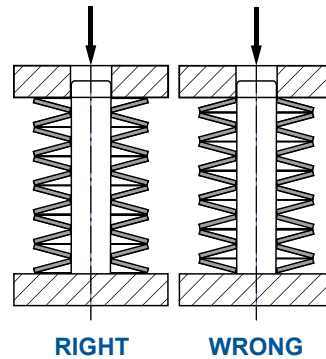

ODD NUMBER OF DISCS

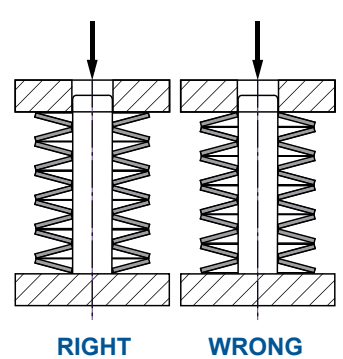

STACK GUIDANCE

To keep the Disc Springs in position the stacks need guiding. The preferred method is internal guidance, such as a rod/mandrel, through the inside diameter. In the case of external guiding, a sleeve is suggested. In either case, the guiding component should be case hardened to 58 HRC with a depth of not less than 0.6mm with a surface finish of ≤ 4 microns.

Since the diameter of the Discs change when compressed, the following clearance values are recommended:

D_e or D_i (mm)	DIAMETRIC CLEARANCE (mm)
Up to 16	0.2
Over 16 to 20	0.3
Over 20 to 26	0.4
Over 26 to 31.5	0.5
Over 31.5 to 50	0.6
Over 50 to 80	0.8
Over 80 to 140	1.0
Over 140 to 250	1.6

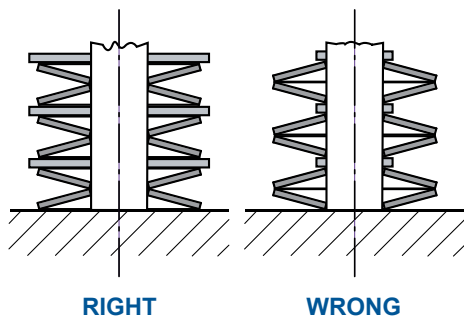

The stability of a Disc Spring with a thickness of 1mm or less can present a problem at the bearing surfaces. In such cases, it is recommended that intermediate flat Discs/Washers are used with outside diameter contact.

Once the Disc Spring stack has been aligned, a light preload should be applied to keep the stack in position. If this is not possible, the stack should be taken to flat condition at least once, as this also has the effect of centralizing the Disc Springs.

Technical Centres

PROGRESSIVE LOAD CURVES

Progressive loading can be obtained by assembling the stacks in which the Disc Springs will deflect consecutively when loaded, by:

- Stacking single, double and triple parallel sets in series.
- Stacking Disc Springs of various thickness in series.

It is necessary to limit the compression of the weaker Disc Spring to avoid over-compression while the stronger Disc Springs, or parallel sets, are still in the process of compressing.

Disc stacks with progressive characteristic load curves and stroke limiters to avoid overload.

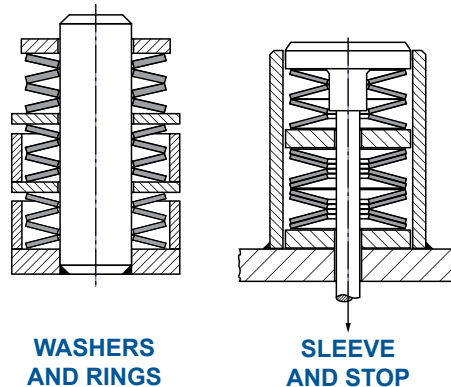

PRE-STACKED

The process of installing Disc Springs stacks in a production environment is generally a manual process. Depending on the stack configuration this is a time-intensive process and introduces an opportunity for errors in the stack configuration. Rather than having to configure and stack Disc Springs manually, manufacturers can specify Pre-Stacked Disc Springs (greased or ungreased). These stacks are packed in shrink-wrap with a perforated tab, allowing a simple installation process that saves time and helps mistake-proof the assembly process.

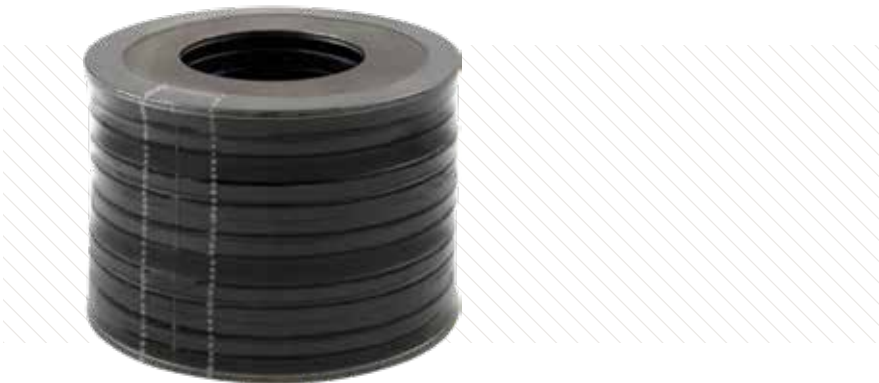

Read how SPIROL Engineers determined the best Disc Spring stacking methods for an overload safety switch on [SPIROL.com](https://www.spirol.com).

Original article by Darren Snell

Europe

SPIROL United Kingdom
17 Princeswood Road
Corby, Northants
NN17 4ET United Kingdom
Tel. +44 1536 444800
Fax. +44 1536 203415

SPIROL France
Cit  de l'Automobile ZAC Croix Blandin
18 Rue L na Bernstein
51100 Reims, France
Tel. +33 3 26 36 31 42
Fax. +33 3 26 09 19 76

SPIROL Germany
Ottostr. 4
80333 Munich, Germany
Tel. +49 89 4 111 905 71
Fax. +49 89 4 111 905 72

SPIROL Spain
08940 Cornell  de Llobregat
Barcelona, Spain
Tel. +34 93 669 31 78
Fax. +34 93 193 25 43

SPIROL Czech Republic
Prask 1847
Slan  274 01
Czech Republic
Tel. +420 313 562 283

SPIROL Poland
Aleja 3 Maja 12
00-391 Warszawa, Poland
Tel. +48 510 039 345

Americas **SPIROL International Corporation**
30 Rock Avenue
Danielson, Connecticut 06239 U.S.A.
Tel. +1 860 774 8571
Fax. +1 860 774 2048

SPIROL Shim Division
321 Remington Road
Stow, Ohio 44224 U.S.A.
Tel. +1 330 920 3655
Fax. +1 330 920 3659

SPIROL Canada
3103 St. Etienne Boulevard
Windsor, Ontario N8W 5B1 Canada
Tel. +1 519 974 3334
Fax. +1 519 974 6550

SPIROL Mexico
Avenida Avante #250
Parque Industrial Avante Apodaca
Apodaca, N.L. 66607 Mexico
Tel. +52 81 8385 4390
Fax. +52 81 8385 4391

SPIROL Brazil
Rua Mafalda Barnab  Soliane, 134
Comercial Vit ria Martini, Distrito Industrial
CEP 13347-610, Indaiatuba, SP, Brazil
Tel. +55 19 3936 2701
Fax. +55 19 3936 7121

Asia Pacific **SPIROL Asia Headquarters**
1st Floor, Building 22, Plot D9, District D
No. 122 HeDan Road
Wai Gao Qiao Free Trade Zone
Shanghai, China 200131
Tel. +86 21 5046 1451
Fax. +86 21 5046 1540

SPIROL Korea
160-5 Seokchon-Dong
Songpa-gu, Seoul, 138-844, Korea
Tel. +86 21 5046-1451
Fax. +86 21 5046-1540

email: info-uk@spirol.com

SPIROL.co.uk